

# VZ-22RTV

## Value Line CCTV Monitor

# ViewZ



### VZ-22RTV

**300cd/m<sup>2</sup>**  
High Brightness

**1000:1**  
High Contrast Ratio

**1680 x 1050**  
60Hz  
Resolution

**5ms**  
Response Time

**Built in Speakers**

|                  |                               |  |
|------------------|-------------------------------|--|
| Display          | Model Name( Screen Size)      | VZ-22RTV (22")   |
|                  | Max. Resolution               | 1680 x1050 @60Hz   |
|                  | Pixel Pitch                   | 0.282 x0.282 mm  |
|                  | Brightness                    | 300cd/m <sup>2</sup>   |
|                  | Contrast Ratio                | 1000:1   |
|                  | Aspect Ratio                  | 16 : 10  |
|                  | Viewing Angle (H/V)           | 160°/160°  |
|                  | Display Color                 | 16.7 Million   |
|                  | Response Time                 | <5ms   |
|                  | Video System                  | NTSC / PAL   |
| Interface        | Frequency (H)                 | 30 ~ 95 KHz  |
|                  | Frequency (V)                 | 55 ~ 75 Hz   |
|                  | Video In/ Out (BNC Type)      | 2 / 2  |
|                  | S-Video In/ Out               | 1 / 0  |
|                  | RGB In (15Pin D-Sub)          | 1  |
|                  | DVI In                        | 1  |
|                  | HDMI In                       | 1  |
|                  | PC Stereo In                  | 1  |
|                  | Audio In (RCA Type)           | 1  |
| Audio Out        | 1                             |  |
| Trigger Input    | 1                             |  |
| Audio            | Built in Speakers             | Yes(2W X 2)  |
| Transmitter      | Remote Control                | Yes  |
| Special Features | Multi Display Function        | PIP / VOV  |
|                  | Filter Type                   | 3D Comb-filter / DeInterlace   |
|                  | LCD Protection Glass          | Optional   |
|                  | Rack Mountable Kit            | Optional   |
| Dimension        | Multi Language                | English, French, German, Italian, Spanish, Danish, Portuguese, Dutch |
|                  | Outline Dimension (W x H x D) | 20.43" x 13.82" x 2.6"<br>(519mm x 351mm x 66mm)                     |
|                  | Net Weight                    | 11.40lbs (5.17Kg)  |
| Cabinet          | Finish/Tilt Stand             | Black /Yes   |
| Mounts           | VESA Mounts Size              | 100 x100 mm<br>(BS M4 x10 mm Screw)                                  |
| Warranty         | Parts/ Labor                  | 2 Year / 2 Year  |
|                  | MTBF(Approx.)                 | 50,000 Hours   |
| Regulations      |                               | TUV-NRTL , CB, FCC(A), CE-Emc(LVD)                                   |
| Power            | Consumption : < On            | < 50W  |
|                  | Electrical Ratings            | AC100 ~ 240V(50/60Hz)<br>DC 12V / 4.2A                               |
| Circumstance     | Operating Temperature         | 32 - 104°F / 0 - 40°C  |

## SPECIAL FEATURES

- Multiple Interfaces:
  - Video In/Out x 2 (BNC type loop through)
  - S-Video In x 1
  - RGB Input (15pin D-sub)
  - Audio In
  - PC Stereo In
  - DVI In / HDMI In x 1
  - Audio Out x 1
  - Trigger In x 1
- 600 TV Lines / 10bits Digital Conversion Rate
- Energy Saving : 1W (Sleep Mode)
- Built-In Speakers
- Multi Display: PIP / PBP / VOV
- Trigger Sensor
- 3D Comb-filter w/ De-Interlace
- Remote Control
- Trigger / Time Buse Switching
- Adjustable Stand (tilt)
- Optional Wall/Rack Mountable

## DEMENSION

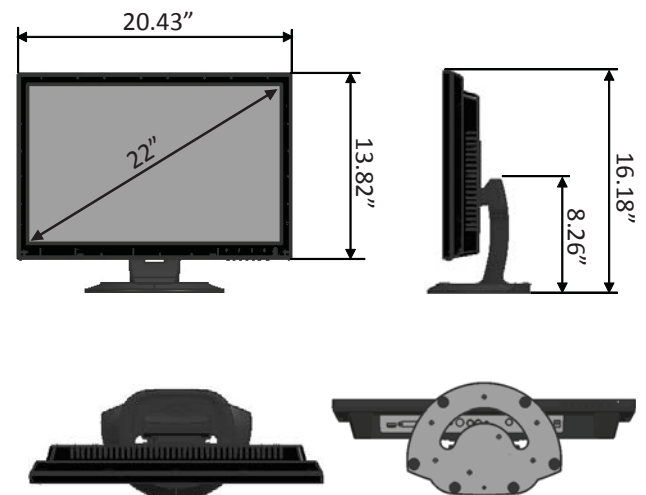

For more product information, visit us on the web at [OrionTech-USA.com](http://OrionTech-USA.com)

1220 N. Kraemer Blvd., Anaheim, CA 92806 | TEL: (714) 630-3380 | FAX: (714) 630-2335